

Specifications/技术参数:

Electrical/电气特性:

Current Rating (额定电流): 3A
 Withstand Voltage (耐压值): 1000VAC for one minute
 Contact Resistance (接触电阻): 20mΩ max
 Insulation Resistance (绝缘电阻): 5000MΩ min
 Operating Temperature (工作温度): -40°C ~ +105°C

Physical/物理特性:

Insulator (塑胶本体): Glass Filled Polyester
 Flammability Rating (防火等级): UL 94V-0
 Contacts (接触件): Copper alloy
 Contacts plating (接触件电镀): Selective gold plating on surface contact area

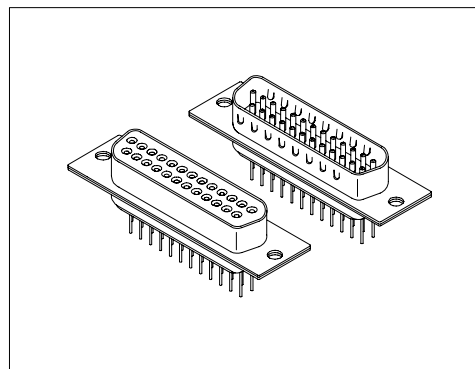

Dimension/尺寸: mm

Male/公针:

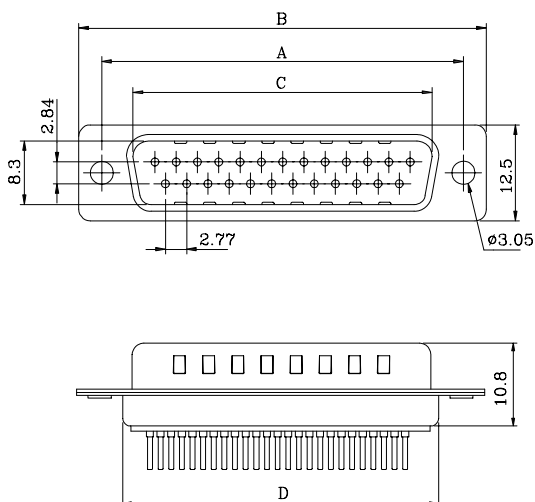

Dimension/尺寸:

Poles	Dim A	Dim B	Dim C	Dim D	Dim E
9	25.0	30.8	16.92	19.2	6.96
15	33.32	39.2	25.25	27.7	6.96
25	47.04	53.1	38.96	41.1	6.90
37	63.5	69.4	55.42	57.3	6.82

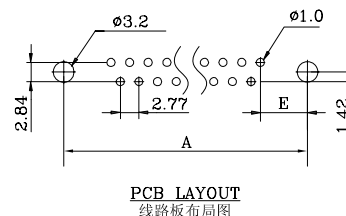

Female/母孔:

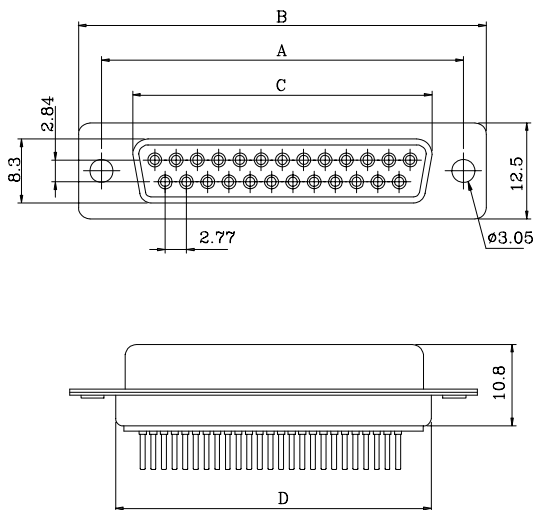

Dimension/尺寸:

Poles	Dim A	Dim B	Dim C	Dim D	Dim E
9	25.0	30.8	16.3	19.2	7.67
15	33.32	39.2	24.6	27.7	6.99
25	47.04	53.1	38.3	41.1	6.99
37	63.5	69.4	54.8	57.3	7.07

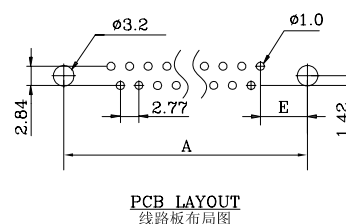

Mounting Options/安装选项:

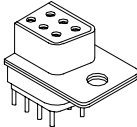
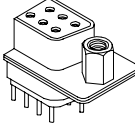
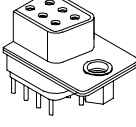
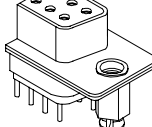
AA Riveted front and rear shell with $\phi 3.05\text{mm}$ Hole	CB Riveted #4-40 UNC close nuts on front shell	CE Riveted #4-40 UNC open nuts on rear shell	CH Riveted #4-40 UNC close ground stand-off on rear shell
 <p>光孔 $\phi 3.05$</p>	 <p>前铆#4-40六角螺柱</p>	 <p>后铆#4-40六角螺柱</p>	 <p>后铆#4-40鱼叉</p>

Ordering Code/订购型号:

1 2 3 4 5 6
DMS — 15 F G — CB — 3

1. Series No./系列号:

DMS

2. Poles/位数:

9、15、25、37

3. Contacts type/接触件类型:

M = Male(公针)

F = Female(母孔)

A = Male machined contact(车制公针)

B = Female machined contact(车制母孔)

4. Contacts plating/接触件电镀:

S = Selective Gold(半金)

G = Gold flash(全金)

G5 = 5μ " Gold(镀金 5μ ")

5. Mounting options/安装选项:

AA = With $\phi 3.05\text{mm}$ holes on shell (带 $\phi 3.05\text{mm}$ 光孔)

CB = Riveted #4-40 UNC close nuts on front shell(前铆#4-40螺丝)

CE = Riveted #4-40 UNC open nuts on rear shell(后铆#4-40螺丝)

CH = Riveted #4-40 UNC close ground stand-off on rear shell(后铆#4-40鱼叉)

6. Insulator color/胶体颜色:

1 = White(白色)

2 = Blue(蓝色)

3 = Black(黑色)

4 = Grey(灰色)